



BODY		
Construction	Unitized steel body with isolated front and rear subframe	
Final assembly location	Oakville Assembly Complex, Oakville, Ontario	
ENGINE		
Type	3.7-liter Ti-VCT V6	3.5-liter EcoBoost® V6
Manufacturing location	Lima Engine Plant, Ohio	Cleveland Engine Plant, Ohio
Configuration	60-degree V6, aluminum block/heads	60-degree V6, aluminum block/heads
Displacement	3.7-liter/227.4 cu. in.	3.5-liter/213 cu. in.
Bore x Stroke	3.7 x 3.4 in./95.5 x 86.7 mm	3.6 x 3.4 in./92.5 x 86.7 mm
Crankshaft	Forged steel	Forged steel
Redline	6,750 rpm	6,200 rpm
Valvetrain	DOHC, four valves per cylinder, intake and exhaust variable camshaft timing	DOHC, four valves per cylinder, intake variable camshaft timing
Compression ratio	10.5:1	10.1:1
Horsepower	300 @ 6,500 (projected)	355 @ 5,700 rpm (premium fuel) (projected)
Torque	275 lb.-ft. @ 4000 rpm (projected)	350 lb.-ft. @ 1,500 to 5,250 rpm (projected)
Recommended fuel	87 octane unleaded	Designed to run on regular fuel with an octane rating of 87 or higher. For best overall performance, premium fuel with an octane of 91 or higher is recommended
Fuel capacity	18.6 gallons	18.6 gallons
Fuel delivery	Sequential multi-port fuel injection	Direct injection
Oil capacity	5.5 quarts with filter	6.0 quarts with filter
Federal standards	Tier 2/Bin 5 tailpipe, LEVII evaporative	Tier 2/Bin 5 tailpipe, LEVII evaporative
California standards	ULEVII tailpipe, LEVII evaporative	ULEVII tailpipe, LEVII evaporative
EPA fuel economy	FWD – 17 mpg city/25 mpg highway (projected)	AWD – 16 mpg city/23 mpg highway (projected)
DRIVETRAIN		
Layout	Front-wheel drive	All-wheel drive
TRANSMISSION		
	Electronic 6F-50 six-speed with SelectShift Automatic™ with paddle shift activation	Electronic 6F-55 six-speed with SelectShift Automatic with paddle shift activation

2013 Lincoln MKT Technical Specifications



Gear ratios: 6F-50 and 6F-55		
1st		4.48:1
2nd		2.87:1
3rd		1.84:1
4th		1.41:1
5th		1.00:1
6th		0.74:1
Reverse		2.88:1
Final drive		3.16:1
SUSPENSION		
Front	MacPherson strut and rear-facing L-shaped lower control arm and stabilizer bar. Computer Controlled Dampers, included with 3.5-liter EcoBoost.	
Rear	Independent multilink suspension with coil-over shock and stamped steel lower control arm. Computer Controlled Dampers, included with 3.5-liter EcoBoost.	
STEERING		
Type	Electric power-assisted steering (EPAS) rack-and-pinion	
Steering column	Tilt /telescoping	
Ratio	15.1:1	
Turns, lock-to-lock	2.65	
Turning diameter, curb-to-curb	42.4	41.5
BRAKES		
Type	Standard four-wheel ABS (four channel) with AdvanceTrac®	
Front	Ventilated disc with vented hat section, 13.86-inches	
Front swept area	150.36 sq. in.	
Rear	Ventilated disc, 13.58-inches	
Rear swept area	133.18 sq. in.	
WHEELS AND TIRES		
Standard	19-in. premium painted aluminum P235/55R19 A/S BSW	19-in. premium painted aluminum P235 /55R19 A/S BSW
Optional	N/A	20-in. polished aluminum P255/45R20 A/S BSW
DIMENSIONS (inches unless otherwise noted)		
Exterior		
Wheelbase	117.9	
Length	207.6	
Width with mirrors	85.7	
Width with mirrors folded	79.9	
Width without mirrors	76.0	
Vehicle height without options	67.4	
Track, front/rear	65.4/65.3	



Interior		
Seating capacity	Up to seven	
Headroom		
Front row	40.1	
Second row	39.0	
Third row	33.5	
Legroom		
Front row	41.3	
Second row	41.8	
Third row	33.0	
Shoulder room		
Front row	58.6	
Second row	58.1	
Third row	49.1	
Hip room		
Front row	55.7	
Second row	55.9	
Third row	40.6	
WEIGHTS AND CAPACITIES (pounds unless otherwise noted)		
Passenger volume	142.3 cu. ft.	
Interior volume	160.2 cu. ft.	
Cargo capacity		
Behind third row including cargo well	17.9 cu. ft.	
Behind second row	39.6 cu. ft.	
Behind first row	75.9 cu. ft.	
Maximum towing capacity (properly equipped)	Class III - 4,500 lbs.	
Base curb weight (projected)		
FWD	4,702 lbs.	
AWD	N/A	4,942 lbs.

Specifications are preliminary and subject to change

2013 Lincoln MKT Technical Specifications

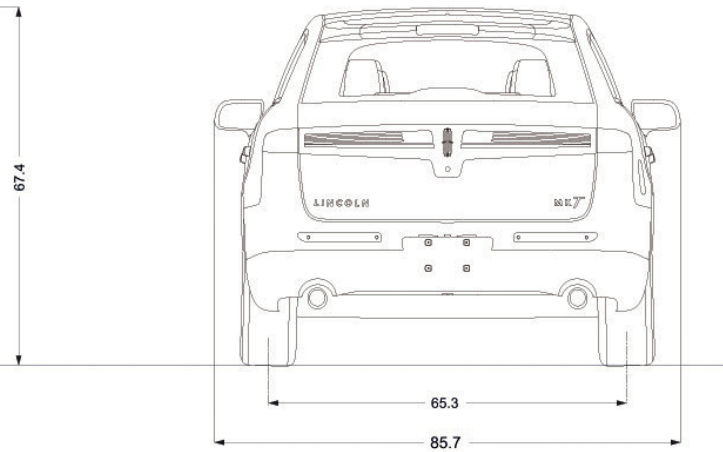
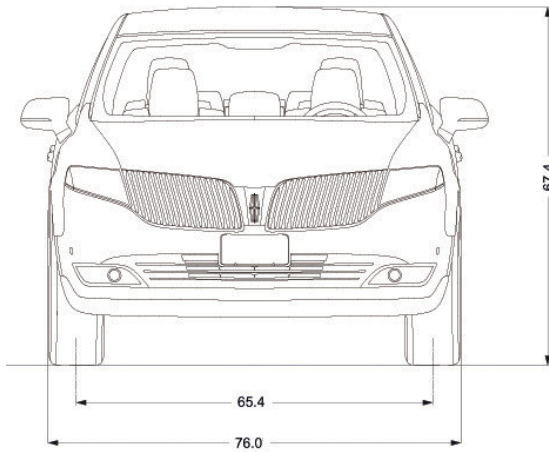
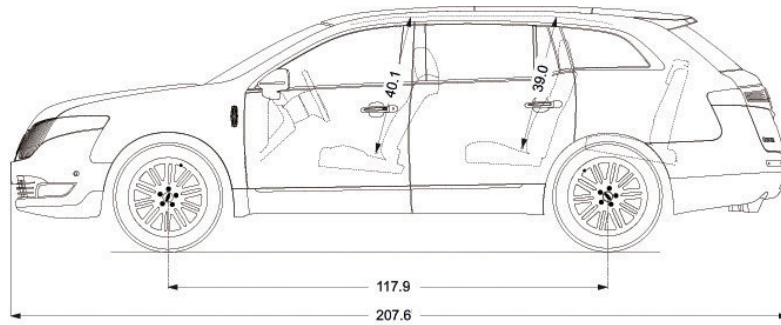

Contacts: Christian Bokich
313.621.2936
cbokich@lincoln.com

Sam Locricchio
646.577.0052
slocric1@lincoln.com

Timothy Elliott
212.614.5180
tellio45@lincoln.com